

3D model management for e-commerce

Helen V. Diez¹ · Álvaro Segura¹ ·
Alejandro García-Alonso¹ · David Oyarzun¹

Received: 27 April 2016 / Revised: 22 September 2016 / Accepted: 5 October 2016 /

Published online: 19 October 2016

© Springer Science+Business Media New York 2016

Abstract This paper contributes to the efficient visualization and management of 3D content for e-commerce purposes. The main objective of this research is to improve the multimedia management of complex 3D models, such as CAD or BIM models, by simply dragging a CAD/BIM file into a web application. Our developments and tests show that it is possible to convert these models into web compatible formats. The platform we present performs this task requiring no extra intervention from the user. This process makes sharing 3D content on the web immediate and simple, offering users an easy way to create rich accessible multiplatform catalogues. Furthermore, the platform enables users to view and interact with the uploaded models on any WebGL compatible browser favouring collaborative environments. Despite not being the main objective of this work, an interface with search engines has also been designed and tested. It shows that users can easily search for 3D products in a catalogue. The platform stores metadata of the models and uses it to narrow the search queries. Therefore, more precise results are obtained.

Keywords Cad · BIM · 3D model conversion · WebGL technology

Electronic supplementary material The online version of this article (doi:10.1007/s11042-016-4047-1) contains supplementary material, which is available to authorized users.

✉ Helen V. Diez
hdiez@vicomtech.org

Álvaro Segura
asegura@vicomtech.org

Alejandro García-Alonso
alex.galonso@ehu.es

David Oyarzun
doyarzun@vicomtech.org

¹ Vicomtech-IK4 Research Center, Paseo Mikeletegui 57, 20009 San Sebastian, Spain

1 Introduction

People involved in e-commerce do not need to have technical background regarding CAD or BIM data. However, they do need to create and manage online catalogues to offer their products and allow potential customers to view and interact with them.

Embedding CAD/BIM data into web-based repositories has a number of challenges in contrast to common element types such as text and images.

- CAD/BIM file formats are not included in web standards and browsers do not directly support them.
- There is no standard 3D model file format that can be embedded in web pages, unlike image or video formats.
- The WebGL 3D rendering API can render polygonal models (triangle meshes), but CAD/BIM models are usually not composed of polygons but are defined in terms of higher complexity parametric shapes.
- When parametric CAD models are transformed into polygonal meshes, the result often contains a large number of polygons and the file is too large for an efficient use by a web client.

The main challenges for using such content on the web are thus to transform CAD/BIM files into formats suitable for web-based handling and rendering, and to present this content to client viewers in an efficient and user-friendly repository. That is, from the point of view of the CAD/BIM designer it has to be easy to add content to the repository. And from the point of view of the visitor, searching, accessing and viewing content has to be easy and quick. The main bottleneck for the last challenge is transfer time. This can be reduced with mesh simplification algorithms, but at the expense of visual quality. The system will have to find a compromise between shape quality and file size (i.e. transfer time).

In order to deal with the above challenges, the integration of CAD/BIM data involves solving several non-trivial issues:

- **Polygonal conversion:** Convert non-polygonal models into a polygonal model. For example, curved surfaces into triangle meshes.
- **Conversion to web compatible file formats:** Convert different native CAD and BIM file formats into a format that can be interpreted and rendered in a web page script.
- **Polygonal mesh simplification and Semantics:**
 - Reduce the number of polygons that describe an object maintaining its appearance and making it suitable for the Web: fast transmission rate and efficient rendering.
 - Keep as much semantic information as possible.

These issues make it difficult to create and update web catalogues. Sales agents and designers, from now on users, have to deal with technical issues that exceed their knowledge field.

The web platform proposed in this paper allows users – with no particular knowledge – to view, manage and interact with complex 3D models. It allows users to upload CAD or BIM models into the web. So, 3D model catalogues for e-commerce can be managed in an easy and intuitive way. It also provides a collaborative mechanism to share models.

The e-commerce oriented platform proposed in this paper solves the issues presented above in an automatic way. It offers a device-independent, interoperable, plug-in free solution. The platform serves the purpose of an online catalogue; users can easily upload their 3D models by simply dragging their native 3D formats into the online platform. The system automatically converts these file formats into a web compatible file format and stores them in a database. WebGL technology has been chosen to render 3D models in browsers.

Even more, this web based platform makes sharing 3D models immediate and creates a collaborative work environment in which anyone with an internet connection enabled device (PC, smartphone, tablet) can interact with the models from the online catalogue.

To overcome these limitations, the platform presented in this paper performs a sequence of operations on the original models to make them adequate to the Web. These operations include tessellation, polygon simplification and scene graph reduction.

To validate the platform, a particular use case has been designed. Several tools have been developed to improve the users experience with the platform; colour tool, measure tool, cut tool and snapshot tool. A search engine has also been included in the application since it is a common and necessary functionality in any online catalogue.

It should be kept in mind that the goal of our work is to prove that the “user-friendly CAD/BIM to Multimedia web based publishing” challenge can be achieved and to propose and validate a possible architecture. The same concept applies to the searching utilities. So, although our work makes use of different geometric and topological tools and algorithms, our contribution is not focused on these problems.

Next Section deals with background regarding the issues stated in the introduction. The proposed platform is described in detail in Section 3. Section 4 presents some results of this work using the proposed platform and finally, Section 5 analyses the conclusions drawn from the results and introduces future work.

2 Background

Sections 2.1, 2.2, and 2.3 address the issues presented in the introduction and Section 2.4 presents some existing platforms.

2.1 Polygonal conversion

BIM and CAD models are normally designed as parametric models. Parametric models offer very precise and realistic models. However, interactive visualization requires converting them into a polygonal representation by approximating these surfaces into many polygons. This process is also known as tessellation.

There are essentially two methods [11, 12] to convert a parametric surface into its polygonal representation.

2.2 Web compatible file formats

These are some of the most widely used CAD exchanging formats:

- AutoCAD DXF [10] (Drawing eXchange Format) is a CAD data file format developed by Autodesk for enabling data interoperability between AutoCAD and other programs.

- IGES [36] (Initial Graphics Exchange Specification) defines a vendor neutral data format that allows digital exchange of information among CAD systems (version 6.0 1998–01–05).
- STEP (STandard for the Exchange of Product) was developed as the successor of IGES; it is an ISO 10303–21 [17] (last reviewed in 2012) standard for the computer-interpretable representation and exchange of product manufacturing information.
- VRML (Virtual Reality Modeling Language) [6] is a text file format where vertices and edges for a 3D polygon can be specified along with the surface colour, transparency, etc.
- In 2001, X3D [38] arrived as an XML encoding of VRML. X3D provides both the XML-encoding and the Scene Authoring Interface (SAI) to enable web applications to incorporate real-time 3D, presentations and controls into non-3D content.
- COLLADA (COLLABorative Design Activity) [9] defines an open standard XML schema for exchanging digital assets among various graphics software applications. Unlike X3D, COLLADA does not define the semantic in the 3D scenes, it is an intermediate format whose primary goal is to represent rich data in multiple forms, to enable the transformation of assets as they journey from content tools that use higher level description paradigms to applications that require platform-specific optimized descriptions [1].

Regarding BIM, Industry Foundation Classes (IFC) is a commonly used collaboration file format. It is an object-based file format with a data model developed by buildingSMART [5] to facilitate interoperability in the architecture, engineering and construction (AEC) industry.

IFC files are SPF (STEP Physical File) or XML representations defined against a schema. The schema gives meaning, names and relations on top of the knowledge contained in the IFC file. IFC4 [18] was released in March 2013.

None of the above formats are directly embeddable in web pages. The challenge is to select one or more native CAD/BIM input formats and to provide a tool that converts them into a format that can be interpreted and rendered in a web page.

2.3 Polygonal mesh simplification and semantics

Algorithms used to simplify meshes are based on the so called simplification operators; the most popular ones are vertex decimation, edge collapsing and vertex clustering.

- Vertex decimation operator was first proposed by Schroeder [31] Vertex decimation operates on a single vertex by deleting that vertex and re-triangulating the resulting hole.
- After vertex decimation, edge collapsing became the most common mesh simplification algorithm, such that today nearly all iterative algorithms use some sort of edge collapsing [15].
- In vertex clustering the bounding box of the mesh is divided into a grid, and all of the vertices in a given cell are replaced with a single representative vertex. Faces that become degenerate are removed from the resulting simplified mesh. Lindstrom [19] showed how Quadric Error Metric (QEM) simplification algorithm can be used to generate higher quality results.

Software tools can also be used to simplify the polygonal complexity of 3D models. Some of these tools work as plug-ins, as stand-alone applications or as programming libraries:

- Polygon Cruncher [28]
- Simplygon [2]
- MeshLab [25]

Considerable research has been conducted on polygonal mesh simplification [8, 22, 23]. Shamir A. [32] presents a state of the art on mesh segmentation techniques, and concludes that the key factor for choosing both the algorithm and the criteria for mesh segmentation is the application in mind. Thakur A. et al. [35] present a list of CAD model simplification techniques relevant for physics-based simulation problems and characterize them based on their attributes. They state that there are many open research issues such as the lack of formal analysis of computational complexity or the lack of application-specific error measures.

Posada J. et al. [29] present an ontology based compression system that uses STEP compliant standards for the compression and design review visualization of large CAD data sets. The introduction of semantics in CAD models has also been analyzed to achieve interoperable systems and exchangeable data [39].

2.4 Related work: platforms

As for visualization technologies are concerned, WebVR is an experimental JavaScript API that provides access to virtual reality devices. This technology has been used to visualize CAD models [37, 40] and also to manage big city information, proving the usability of such technology for 3D city visualization [20].

As applications are concerned, CyberCAD [34] in 2003 aimed to establish a virtual synchronous collaborative design environment to overcome geographical constraints, shorten product development time and cost through the Internet. This project developed a proprietary framework for networked CAD.

Han et al. [14] built a pilot real-time 3D system to promote the Internet-based collaborative engineering design (modelling) using STEP standard to store database. The system provides a web-based search tool with the concept of metadata for navigating the product data.

Lu, Zhihan et al. [21] proposed Open3D platform to enable the collaborative curation of large-scale city models. This platform allows simultaneous city modelling allowing multiple users to work on different aspects of the same 3D model.

GrabCAD [13] was founded in 2009 as a marketplace to connect engineers with CAD-related jobs. In 2011 it evolved into a community for engineers to share CAD models. It is short of social network where engineers can create a personal profile, store different projects, view, upload and download models from other members, communicate with each other and collaborate in other user's projects. In 2013, GrabCAD released Workbench, a cloud-based product data management (PDM) solution. This platform offers visualization of CAD models using original format viewers. This workbench offers visualization of CAD models using original format viewers. One of its features is section cutting. They resolve this issue by applying shaders to the visualization of the 3D model. However, we perform an accurate geometric cut of the model applying Binary Space Partitioning algorithm [16, 26].

BIMserver [4] is an open and stable software core to easily build reliable BIM software tools. BIMserver uses open standards, it is built as a plug-in framework and it offers an administrator configuration panel and SDKs. It features a number of modules such as visualizations, clash control and flexible queries. The platform has been installed in several companies for test purposes and feedback has been provided by developers and mailing list

subscribers. BIMserver is therefore a very specialized solution for AEC industry. On the other hand, our platform is oriented to multimedia service.

The systems currently available do not provide a solution to the objectives described in the introduction of this paper. There was a need to find solutions that allowed a user-friendly connection between CAD systems and online marketing applications.

In the long run, our work does not intend to compete with commercial platforms. Our research work shows that there are new challenges that should be addressed by them. Meanwhile our research tools can provide a useful service. We hope that our work may push the industry towards these new challenges. We hope user-friendly CAD/BIM to Multimedia web based publishing and searching tools might become common tools in the near future.

3 The proposed platform

In this Section, we present a platform design that provides a structured solution to the problems related to e-commerce catalogues.

The platform is designed following a client-server model. To ensure interoperability between modules, the platform is based on Web Services technology. Specifically, SOAP messaging protocol is used.

The above mentioned functionalities will be composed by three software modules within a common platform: Authoring Tool, Web Visualization Tool and Content Management. Section 3.1 explains the geometric issues taken into account to perform the Authoring Tool, Section 3.2 describes the Web Engine developed for the platform, Section 3.3 deals with semantic issues and finally, Section 3.4 briefly introduces the Content Manager module (Fig. 1).

3.1 Geometric issues

As mentioned above, CAD/BIM models contain complex modelling descriptions and structures. These models are defined by primitives, surfaces, curves, etc. In real time, 3D rendering models must be represented as flat polygons, normally triangles, so curves, spheres, cylinders, etc. must be approximated to polygonal meshes. These polygons are normally subdivided into triangle sets so that the graphics hardware can render them onto the screen.

Real time graphics rendering engines are libraries used to ease application development. They include functionalities such as loading models, scene and camera management, animations, visual effects, etc. These libraries support polygonal formats which are oriented to interactive visualization. Therefore, CAD formats are not usually supported natively by the graphical engines.

Hence, the proposed platform must take a CAD/BIM format as an input and convert it into a web 3D compatible file format. Figure 2 illustrates the whole automatic process followed since the reception of the original CAD file until the web visualization of the 3D model. Decisions taken to accomplish this process are explained bellow.

Many CAD design programs own proprietary formats which cannot be interpreted by other applications. However, as mentioned in Section 2.3, these programs also support 3D standard file formats. Table 1 lists the exporting file formats supported in the most common CAD applications.

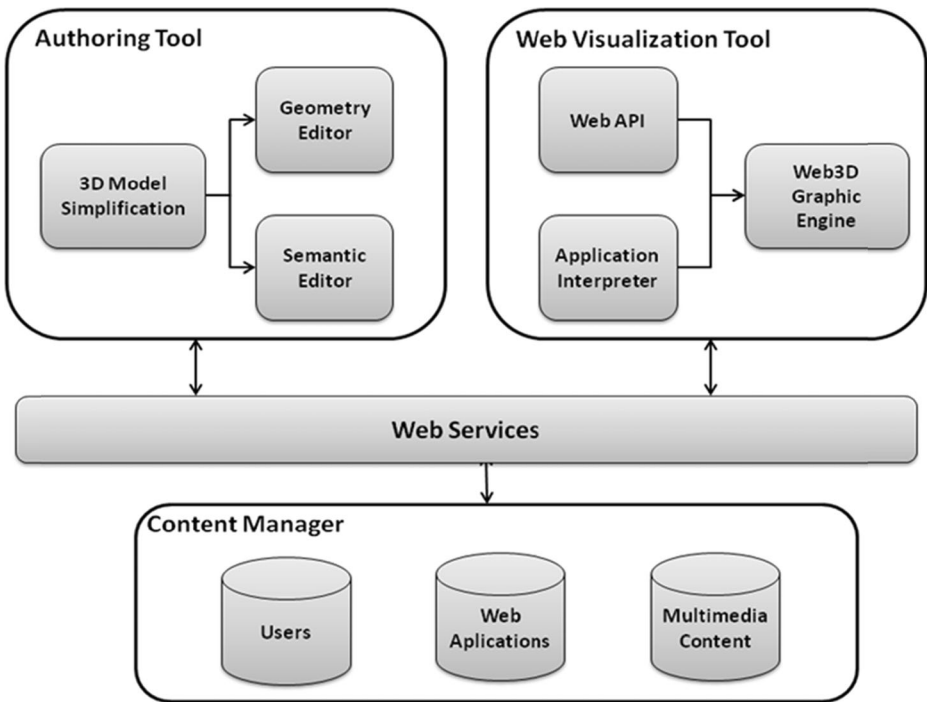

Fig. 1 3D Model Management Platform Architecture

STL, U3D, VRML, OBJ and COLLADA are polygonal file formats for visualization purposes, not CAD specific. But they are supported by some CAD applications. As shown in Table 1, the file formats supported by all applications are IGES and STEP. This fact simplifies the conversion process. Hereafter for the rest of the paper, any CAD or BIM file will be treated as a STEP file, since there is a valid exporting option to obtain a STEP file.

However, CAD programs export IGES models not only as polygonal meshes: they also use primitives and complex curves to define the 3D model. In order to use IGES as input to the platform, a tessellation process must be performed.

Graphics processing libraries have been used to make these conversions. Open CASCADE [27] and OpenSceneGraph [24] have been selected. Open CASCADE Technology is a software development platform applied in development of specialized CAD/CAM/CAE applications. On the other hand, OpenSceneGraph is an open source high performance 3D graphics toolkit, used by application developers in fields such as visual simulation, games, virtual reality, scientific visualization and modeling.

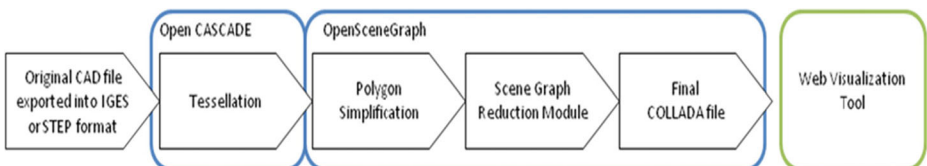

Fig. 2 Original CAD model conversion into Web compatible format

Table 1 Exportable formats in a selection of CAD software

		CAD application				
		SolidEdge	SolidWorks	CATIA	Unigraphics	Pro-Engineering
File Format	Parasolid	×	×			×
	JT	×			×	×
	ACIS	×	×			×
	CATIA	×		×		×
	IGES	×	×	×	×	×
	STEP	×	×	×	×	×
	ProE-assem		×			
	STL	×	×	×		
	U3D	×	×			×
	VRML		×	×	×	
	OBJ					×
	COLLADA					

As shown in Table 2 STL format is the only exchangeable format between these two libraries.

Finally, as mentioned in the introduction, WebGL technology has been chosen to render 3D models into web browsers. A higher level library must be chosen to ease the programming job. Table 3 shows the formats supported by some of these higher level JavaScript libraries.

Taking the afore-mentioned information into account, the process developed to convert original CAD/BIM models into web 3D compatible models is explained in the following paragraphs.

First, the original CAD/BIM models are exported into IGES or STEP files, since these two file formats are supported by most commonly used software. Then, OpenCASCADE is used to tessellate or triangulate these files. CAD/BIM complex primitives and surfaces are

Table 2 Import/Export file formats in open CASCADE and OpenSceneGraph

		Graphics Library / Engine	
		OpenCASCADE	OpenSceneGraph
File Format	Parasolid	×	
	JT		
	ACIS	×	
	CATIA		
	IGES	×	
	STEP	×	
	ProE-assem		
	STL*	×	×
	U3D*		
	VRML*	×	×
	OBJ*		×
	COLLADA*		×

Table 3 Formats supported by JavaScript libraries

		High level Web Library			
		X3DOM	O3D	GLGE	Three.js
File Format	X3D	×			
	COLLADA		×	×	×
	OBJ			×	
	JSON		×		×
	UTF8				×

approximated into triangles obtaining a polygonal mesh. This process is controlled by modifying the tessellation process. Increasing the level of quality parameter, the obtained result will be more similar to the original 3D model but at the cost of having more triangles, and hence, an oversized file. Lower quality value generates smaller and easier to handle files. To finish this part of the conversion process, the tessellated results are exported to STL format, which as seen in Table 2 is an exchangeable file format between Open CASCADE and OpenSceneGraph.

Next, OpenSceneGraph is used to import this STL file, optimize it and convert it into a COLLADA file.

The optimization process joins equal or very close vertices. This process reduces the number of vertices obtaining a simplified mesh. Deleting too many triangles may result in a deformed model with little resemblance with the original. To prevent this undesired effect, an approximation error parameter is set. This parameter will control the balance between the simplification obtained and the shape accuracy.

This optimization process requires a high amount of memory. In order to address this issue, a batching utility has been developed. When the system has to deal with a largest STL file, it is automatically divided into smaller text files; each of which contains a section of the original geometry. Each sub-file is optimized following the process previously explained. After every sub-file has been optimized they are converted into COLLADA file format and merged into one single file containing the optimized model.

This COLLADA file is sent to the web client where it must be loaded and parsed by JavaScript graphic software. ASCII file formats are not particularly efficient to store huge data sets as those required to describe 3D models (space coordinates, vertices, normals, texture coordinates, colours, etc.). These ASCII files may also contain duplicated or too precise information regarding geometries or vertices. To solve these problems and speed up the interpretation of text files a Scene Graph Reduction Module (SGRM) has been developed.

This SGRM module performs, among others, the following optimizations to de COLLADA file:

- *Fixed point precision.* The precision of vertex coordinates, texture coordinates and normal vector coordinates can be controlled.
- *Coordinate or normal vector simplification.* The SGRM searches for duplicated groups of coordinates or normal vectors; it leaves only one group and references the rest.
- *Geometry simplification.* The SGRM searches for duplicated geometries; it leaves only one and references the rest.

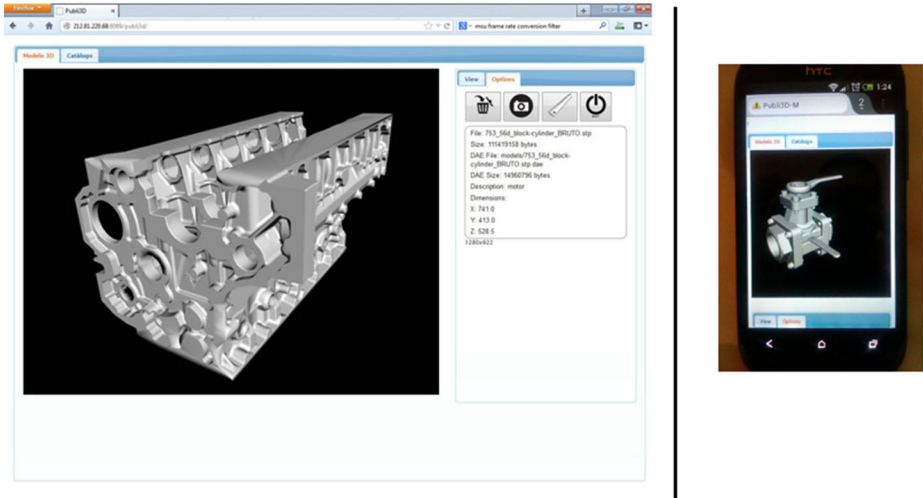

Fig. 3 Web Visualization Tool a Firefox web browser and b Smartphone

- *Multi-material simplification.* Some objects with multi-materials are not well interpreted by browsers, so the SGRM may simplify them.

Finally, this pre-processed COLLADA file is sent to the web application for rendering.

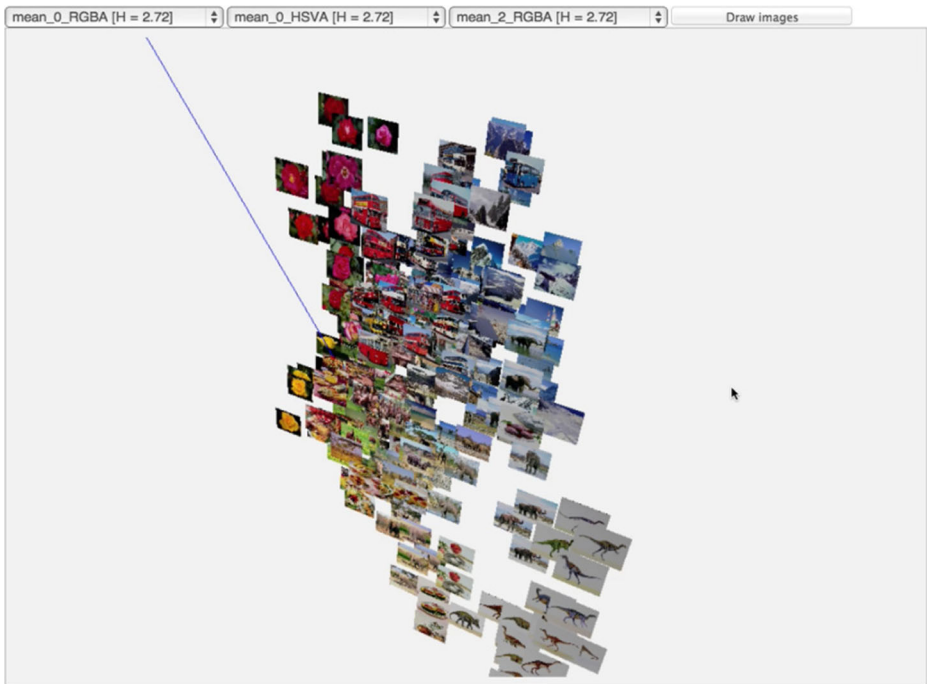
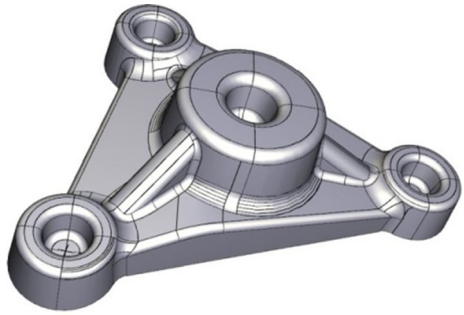

Fig. 4 Image cloud distributed in a 3D space. Images are grouped based on 3 descriptors regarding their colour similarity

Fig. 5 Original STEP model
(1.2 MB, 2145 vertices)



3.2 Web3D engine

The engine developed in this work uses the very well-known Three.js library. This engine is used to visualize the 3D model on a web browser (Fig. 3). The engine offers the following functionalities:

- 3D Model loading. Three.js includes a function to load COLLADA models. Nevertheless, this function has been slightly modified to prevent errors reading the textures of materials.
- Real time rendering. Three.js library provides backends for Canvas, SVG, CSS and WebGL. This platform uses the WebGL backend to render the models. This allows creating complex 3D scenes in a much simpler way.
- Interactivity. Several functionalities have been designed so that users can interact with the 3D models in various ways.
- Camera controls: In order to explore the CAD/BIM model, users can interact with the model; zoom in, zoom out, view it from different perspectives, etc.
- Cut tool: With this tool the user can perform several cuts to the 3D models. When this functionality is activated, a cutting plane is visualized over the model. The user can interact with this plane with three degrees of freedom to perform and visualize different cuts on the model.
- Measure tool: Picking is used to select different faces or points of the model. This information is then used as a measuring tool, calculating the distance or the angle between the selected faces.

Fig. 6 Tessellated model;
high quality selected
(154,000 polygons)

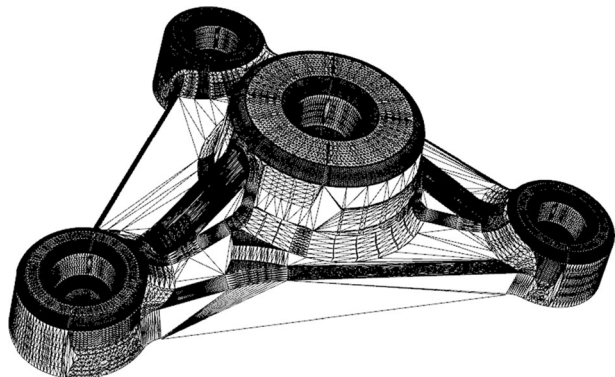
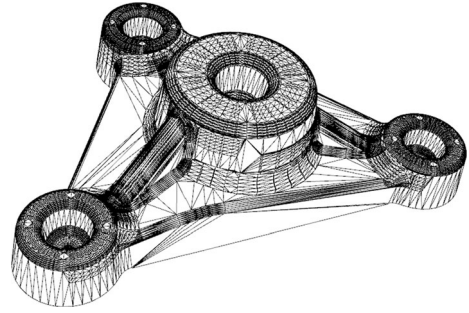

Fig. 7 Tessellated model; medium quality selected (42,069 polygons)



- Snapshot tool: The user can choose to store a thumbnail of the CAD model. This tool allows taking a snapshot of the model in the desired position and associating this image with the metadata of the model.

3.3 Semantic issues

The following Section addresses the problem of storing and searching for the previously loaded 3D models.

CAD models contain metadata which typically provide semantic information including a brief description of the data set, the area covered by the data set, the data structure and file format, the coordinate system or projection of the data, the time when the data was collected and method of collection or the quality or accuracy of the data.

On the other hand, in Computer Vision, image descriptors describe certain elementary characteristics of the images such as shape, colour, texture or size. The advantage of these descriptors is that they can be mathematically compared: similar images will have similar descriptors. This quality is widely used by search engines for 2D image classification.

In our case, 3D projections are stored with the CAD/BIM converted model as metadata. These projections can be generated automatically. Users can easily take snapshots of specific views and store them. These images can be used by classical image classification systems. In this way, content based retrieval processes can be integrated into our platform [30] (Fig. 4).

Fig. 8 Simplified polygonal model (10,340 polygons)

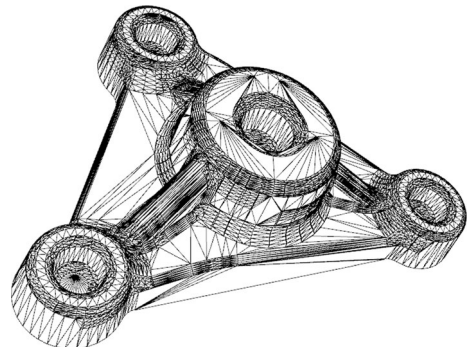

Fig. 9 Tessellated model
(579 MB, 2.2 million polygons)



When the user takes a snapshot of the loaded 3D model, this image is stored in Cloudinary. It is a proprietary cloud platform to manage large numbers of images. Each image file is associated with a unique identifier and URL. Cloudinary extracts the main metadata from the images (codec, size, etc.). Clearly, this data offered by Cloudinary is not enough to search images by similarity. The Semantic Editor Module proposed in this work adds content descriptors: colour and texture histograms and number of detected faces and their orientation.

In essence, the descriptor of each image is a vector of numbers that represents all those features. The enriched metadata is stored in a MongoDB database in the cloud. When a user initiates an image search in our platform a query with the searching criteria is sent. The platform then retrieves all the images from the database with similar features to the one in the query.

A way to evaluate the level of similarity between the retrieved images is to calculate the Euclidean distance between the descriptors in the query and those from the result. As mentioned before, these descriptors are represented as a vector of numbers so their Euclidean distance can be easily obtained.

The Semantic Editor Module in this work calculates the distance between the image used in the query and those in the database and retrieves the 20 more similar images. This collection is done applying the methodology proposed by Silva, J. L. [33] which is based on a probabilistic k-nearest neighbour supervised classification algorithm.

3.4 Content management

The platform presented in this work serves as an online marketing catalogue. The contents of this catalogue are stored in a MongoDB database. MongoDB [7] is a cross-platform document-oriented database system. Classified as a NoSQL database, MongoDB eschews the traditional

Fig. 10 Simplified model
(852,393 polygons)



table-based relational database structure in favour of JSON-like documents with dynamic schemas, making the integration of data in certain type of applications easier and faster. These databases hold a set of *collections* and these collections hold a set of *documents*. A document is a set of key-value pairs. Documents have dynamic schema which means that documents in the same collection do not need to have the same set of fields or structure, and common fields in a document collection may hold different type of data.

The designed database has a collection named *catalogue* in which all the information regarding the 3D models is stored. When a new model is uploaded into the platform a new document is added to the catalogue collection. Initially, these documents are described only by two fields; name and description. These fields are edited by the user when uploading a new model. When the model has been processed as explained in Section 3.1, extra information regarding various aspects (optimized size, path, snapshot image, etc.) is added to this document.

4 Results

This Section presents the platform proposed in this paper using two examples.

4.1 Simple STEP model conversion

The input for this first example is a simple STEP file. As seen in Fig. 5 this model has not been designed with a very high detail. The number of vertices used to define its surface is very low: 2145 vertices. However, it includes surfaces which must be processed for interactive visualization. The first automatic step tessellates this file, approximating its surfaces to triangulated meshes. In Fig. 6 a high quality tessellation is shown with 154,000 polygons. This number can be reduced selecting a lower quality level. With medium quality for this model achieved 35,700 polygons (see Fig. 7).

It may happen that a huge polygonal STEP file does not contain the original surfaces description. In these cases, the scene graph reduction module is applied to the tessellated model. Triangles and vertices are deleted maintaining a bounded approximation error.

Table 4 Conversion Times for model #1.



	Size (KB)	Time (s)
Initial	87	Transfer: 0.0.10
Tessellation	128	0.158
Polygon Simplification	30	0.143
Optimization (SGR)	24	0.199

Final number of Polygons: 1,374

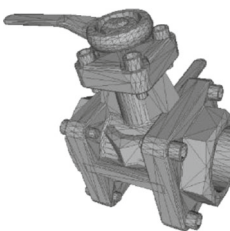
Table 5 Conversion Times for model #2.

	Size (KB)	Time (s)
Initial	1,120	0.035
Tessellation	20,101	2.015
Polygon Simplification	1,623	3.543
Optimization (SGR)	1,325	0.566

Final number of Polygons: 77,355

Using the previous model (35,700 polygons), an automatically simplification achieves a model with 10,340 polygons (see Fig. 8).

4.2 Complex STEP model conversion

The following example presents a much more complex situation. The initial input model in this example is a 165 MB STEP file. Its tessellated result, shown in Fig. 9, is composed by 2.2 million polygons and its STL ASCII file size is 579 MB. The model is too heavy and complex to be visualized even by a native desktop application. Following the algorithm described in Section 3, the model is automatically split in various sub-models and treated separately. In this case, the model was divided into 15 sub-models. Each of these pieces was processed and finally these pieces were merged to obtain the resulting optimized file (see Fig. 10).

4.3 Conversion time rates

This section shows the time needed to convert several CAD models of diverse size and complexity into COLLADA web compatible format. Each example includes the size of the models (KB) after each conversion/optimization process and the final number of polygons (units).

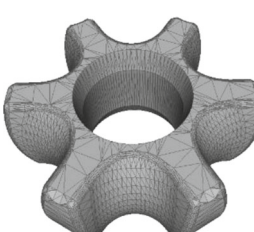
Table 6 Conversion Times for model #3.

	Size (KB)	Time (s)
Initial	2,245	0.069
Tessellation	5,350	1.559
Polygon Simplification	557	2.512
Optimization (SGR)	459	0.084

Final number of Polygons: 18,831

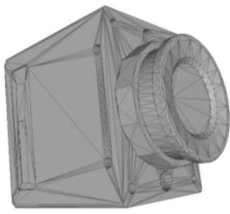
Table 7 Conversion Times for model #4.

	Size (KB)	Time (s)
Initial	22,296	0.282
Tessellation	34,192	15.940
Polygon Simplification	4,463	5.016
Optimization (SGR)	3,748	0.789

Final number of Polygons: 229,887

A medium quality level of conversion has been applied to these models. As defined in Fig. 2 the conversion process includes:

- Tessellation
- Polygon simplification
- Optimization or Scene Graph Reduction (SGR)

As shown in the following examples, tessellation and polygon simplification are the most time consuming steps of the process (see Tables 4, 5, 6, 7, 8, 9 and 10).

Next we analyse the most attention-getting data of these examples.

The size of the models after the tessellation process is bigger than the initial size. Original CAD/BIM files are defined as parametric models; these curved surfaces must be converted into polygons. In order to obtain a precise approximation of the model, a vast number of polygons is needed. However, this model is used as an intermediate process of the conversion. It is not transferred at any time.

In most cases, the size of the final multimedia file is smaller than the original one. However, in Table 5 the final size of the converted model is slightly bigger than the initial size. This happens with models designed in high detail. In order to preserve the appearance of the original model, a bigger amount of polygons is needed and the final size might be slightly

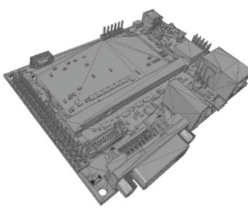
Table 8 Conversion Times for model #5.

	Size (KB)	Time (s)
Initial	62,006	0.767
Tessellation	70,253	107.329
Polygon Simplification	3,538	67.093
Optimization (SGR)	2,888	0.445

Final number of Polygons: 193,323

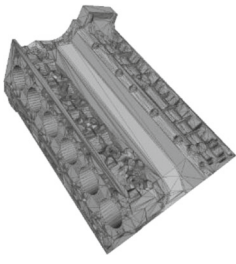
Table 9 Conversion Times for model #6.

	Size (KB)	Time (s)
Initial	108,808	1.196
Tessellation	530,791	149.263
Polygon Simplification	13,025	573.354
Optimization (SGR)	10,827	0.609

Final number of Polygons: 486,579

increased. However, the size of the converted models remains manageable for multimedia transmission purposes.

5 Conclusions and future work

This paper presents a platform for CAD and BIM model management for online marketing. It eases the development of e-commerce systems that contain catalogues with 3D content. As stressed in the introduction, the goal of this work is to offer a user-friendly CAD/BIM to multimedia web based publishing solution and to solve some of its challenges.

The platform has been tested with diverse CAD and BIM models from different locations, devices, operating systems and browsers. The platform has been tested both through wired internet connection and through 3G mobile connection.

The import process considers automatic primitive tessellation, mesh reduction, huge model splitting, scene graph reduction and Web3D compatible model generation (COLLADA).

Model uploading rates vary depending on the size of the model: light models (90 KB) take only a few milliseconds to upload (example in Table 4), however larger files (160 MB) can take up to 20 min (example in Table 10). Then, converted models are smoothly managed and rendered in the client side.

Table 10 Conversion Times for model #7.

	Size (KB)	Time (s)
Initial	165,613	1.749
Tessellation	881,030	356.989
Polygon Simplification	19,934	1002.751
Optimization (SGR)	16,199	1.653

Final number of Polygons: 852,393

To test the platform various models have been dragged and dropped onto the web application. Loading rates on the client vary between a few seconds and a few minutes depending on the size of the file. Large files can be compressed to reduce the loading times [3].

Tests have been made on Mozilla Firefox version 45 and Google Chrome version 50 browsers. Additionally, the platform has also been tested, except the model loading functionality, on smartphones with Android operating system and Firefox Mobile or Chrome Mobile browsers.

A solution for 3D model management has been considered based on virtual 2D images of the 3D models, evaluating image descriptors.

As for future work there are several points to work on, for instance, a level-of-detail based simplification software could be used: a few models with different quality rates could be generated. Later on, depending on the client specifications the most appropriate ones would be sent for local visualization. Regarding model materials there is also further research to be done; intelligent scene graph reduction could be implemented by merging geometries with the same material. The platform is ready to provide model management based on an appropriate image descriptor analysis. Better descriptor and image search tools are being researched to integrate them in the platform.

References

1. Arnaud, R., and Parisi T. (2007). "Developing web applications with collada and x3d." White paper.
2. Automagic 3D Optimization. Simplygon. <http://www.simplygon.com/Accessed> 30 Mar. 2015.
3. Bayardo, R. J., Gruhl, D., Josifovski, V., and Myllymaki, J. (2004). "An evaluation of binary xml encoding optimizations for fast stream based xml processing". In Proceedings of the 13th international conference on World Wide Web, pp. 345–354. ACM.
4. Beetz, J., van Berlo, L., de Laat, R., and van den Helm, P. (2010). BIMserver.org—An open source IFC model server. Proceedings of the CIP W78 conference.
5. Building SMART, U. K. (2010) Investing in BIM competence Building SMART: a guide to collaborative working for project owners and building professionals. Endeavour, UK
6. Carey, Rikk, and Gavin Bell. (1997). "The annotated VRML 97 reference."
7. Chodorow K (2013) MongoDB: the definitive guide. O'Reilly Media, Inc.
8. Cignoni P, Montani C, Scopigno R (1998) A Comparison of Mesh Simplification Algorithms. *Comput Graph* 22(1):37–54
9. COLLADA 3D Asset Exchange Schema. <https://www.khronos.org/collada/>. Accessed 16 April 2015.
10. DXF Reference (2007): 1–296
11. Frey PJ, George PL (2000) "Mesh Generation. In: Application to Finite Element". Hermes Science Publishing, Paris, Oxford
12. George PL, Borouchaki H (1997) Triangulation de Delaunay et maillage: applications aux éléments finis. Hermes, Paris
13. GrabCAD Helps Mechanical Engineers Build Great Products Faster. (2015). CAD Collaboration Solution That Accelerates Product Development.

14. Han S, Choi Y, Yoo S, Park N (2002) Collaborative engineering design based on an intelligent STEP database. *Concurr Eng: Res Appl* 10(3):239–250
15. Hoppe, H., DeRose, T., Duchamp, T., McDonald, J., and Stuetzle, W. (1993). "Mesh optimization". In *Proceedings of the 20th annual conference on Computer graphics and interactive techniques*. pp. 19–26. ACM.
16. Hughes, J. F., Van Dam, A., Foley, J. D., and Feiner, S. K. (2014). "Computer graphics: principles and practice". Pearson Education.
17. ISO, ISO. "10303–21: 2002." *Industrial Automation Systems and Integration–Product Data Representation and Exchange–Part 21*: 72.
18. Liebich, T. (2013). "IFC4 – the new building SMART Standard". http://www.buildingsmart-tech.org/specifications/ifc-releases/ifc4-release/buildingSMART_IFC4_Whatsisnew.pdf. Official Release Date of building SMART's IFC4–12". Date of ISO 16739–21.
19. Lindstrom, P. (2000). Out-of-core simplification of large polygonal models. *Proceedings of the 27th annual conference on Computer graphics and interactive techniques*. ACM Press/Addison-Wesley Publishing Co.
20. Lu Z, Li X, Zhang B, Wang W, Zhu Y, Hu J, Feng S (2016a) Managing big city information based on WebVRGIS. *IEEE Access*, vol 4:407–415
21. Lu, Z., Guerrero, P., Mitra, N. J., and Steed, A. (2016b). Open3D: crowd-sourced distributed curation of city models. In *Proceedings of the 21st International Conference on Web3D Technology*. pp. 87–94. ACM.
22. Luebke D. (2001). "A developer's survey of polygonal simplification". In *IEEE Virtual Reality Conference Tutorial Vol 7*.
23. Luebke D (2003) *Level of Detail for 3D Graphics*. Morgan Kaufmann
24. Martz, P. (2007). "OpenSceneGraph quick start guide." PMARTZ Computer Graphics Systems.
25. MeshLab. MeshLab, the Mesh Processing System for 3D Scanning and Printing. <http://meshlab.sourceforge.net/> Accessed 30 Mar. 2015.
26. Naylor BF (2005) Binary space partitioning trees. *Handbook of Data Structures and Applications* pp:20–21
27. Open CASCADE Technology, 3D Modeling & Numerical Simulation.. <http://www.opencascade.org/> Accessed 30 Mar. 2015.
28. Polygon Cruncher for 3ds Max / 3ds Max Design, Maya, Lightwave, 3D Browser and as a Stand Alone Software. <http://www.mootools.com/plugins/us/polygoncruncher/index.asp> Accessed 30 Mar. 2015.
29. Posada J, Toro C, Wundrak S, Stork A (2006) Using ontologies and STEP standards for the semantic simplification of CAD models in different engineering domains. *Appl Ontol J* 1(3–4):263–279
30. Quartulli M, Olaizola IG (2013) A review of EO image information mining. *ISPRS J Photogramm Remote Sens* 75:11–28
31. Schroeder, W. J., Zarge, J. A., and Lorensen, W. E. (1992) Deci-mation of triangle meshes. *Siggraph Computer Graphics*. Vol. 26. No. 2. ACM.
32. Shamir A (2008) A survey on mesh segmentation techniques. *Computer Graphics Forum* 27(6):1539–1556
33. Silva JL, Bengoa NA, Quartulli M, Olaizola IG, Zulueta E (2015) Web-Based Supervised Thematic Mapping. *IEEE J Sel Top Appl Earth Obs Remote Sens* 8(5):2165–2176
34. Tay, F.E.H., and Roy, A. (2003). CyberCAD: a collaborative approach in 3D–CAD technology in a multimedia-supported environment. *Computers in Industry*, 52 vol. 2 pp. 127–145
35. Thakur A, Banerjee G, Gupta SK (2009) A survey of cad model simplification techniques for physics-based simulation applications. *Comput Aided Des* 41(2):65–80
36. US Product Data Association. (1996). "Initial Graphics Exchange Specification. IGES 5.3." ANSI.
37. Wei-dong WU (2010) Research and Application of Engineering Drafting Teaching Mode based on Technology of Three Degree CAD [J]. *Sci Technol Inf* 23:479
38. X3D V3.3 Abstract Specification. <http://www.web3d.org/content/x3d-v33-abstract-specification>. (2013). Accessed 20 April 2015.
39. Yang QZ, Zhang Y (2006) Semantic interoperability in building design: Methods and tools. *Comput Aided Des* 38(10):1099–1112
40. Zhang, M., Lv, Z., Zhang, X., Chen, G., and Zhang, K. (2009) Research and Application of the 3D Virtual Community Based on WEBVR and RIA. *Computer and Information Science*, vol. 2, no 1, p. 84.



Helen V. Diez received a M.S. degree in Telecommunication Engineering from the University of Navarra, Donostia-San Sebastian, Spain, in 2009. In 2013 she received a Master in Advanced Computer Systems from UPV-EHU. In 2010 she joined Vicomtech-IK4 as a Researcher, working on interactive 3D visualization, simulation, computer vision and Web3D. She is currently a researcher at the Interactive Computer Graphics department of Vicomtech-IK4. Her current research interests include virtual reality, human-computer interaction, 3D visualization and BIM.



Álvaro Segura received a M.S. degree in Electrical Engineering from the University of Navarra, Donostia-San Sebastian, Spain, in 1999. From 1998 to 2001 he worked as a Junior Researcher for San Sebastian's Technology Park, on interactive Web technologies, including 3D graphics, and then on intelligent mobile robotics, including visual and audio perception and navigation. In 2002 he joined Vicomtech-IK4 as a Researcher, working on interactive 3D visualization, simulation, computer vision, GIS, Web3D and computational geometry. He is currently a Principal Researcher at the Industry and Advanced Manufacturing department of Vicomtech-IK4. His current research interests include virtual reality, 3D visualization, simulation and interaction.



Alejandro García-Alonso Mechanical Engineer (U. Navarre, 1980), Ph. D. (U. Navarre, 1990), research assistant (CEIT, 1983), research leader (CEIT, 1992), associate professor of computer graphics (Euskal Herriko Unibertsitatea, 1995), vice Dean Computer Science Faculty (2008). He has collaborated in seven books, two video, seventeen papers in journals, six invited conferences, more than fifty conference communications, supervisor in ten Ph. D., collaborates with many research institutions (CEIT, Tecnalia, Ikerlan, VICOMTech). He has imparted invited lectures in ten universities (USA, Canada, Europe), worked or directed many I+D projects for the industry: Mechanical Dynamics Inc. -MDI, Michigan- (i.e. “ADAMS/Animation”), Aerospaciale, Alenia, CASA, (i.e. “Distributed Simulation for Visualization of Space Activities in Near-Real-Time”, 1995), European Space Agency (“Investigations in the Production of Realistic 3D Scenes. Survey of Methods and Algorithms”, 1986). He has collaborated with more than thirty companies. His research interests include computer graphics, virtual reality, geometric problems (collisions), and haptics. He is a member of the IEEE, ACM, and Eurographics.



Dr. David Oyarzun is the director of the Interactive Computer Graphics Department at Vicomtech-IK4. He studied Computer Engineering in the University of the Basque Country. He received his Ph.D. in the field of 3D Virtual Environments standardization from the University of the Basque Country. From 2001 to 2003 he gained experience in topics such as biometric access, control systems for networks or Artificial Intelligence. From 2003 onwards he is working at Vicomtech-IK4. He is also member of the Board of Directors of Web3D Consortium. He has dozens of publications in topics related with Virtual and Augmented Reality in international conferences and journals, and he is also regular member of several IPCs. Moreover, he is external advisor of ANEP, the Spanish Agency that evaluates some of the main national R&D calls for projects.